

1 2 3 4 5 6 7 8 9 10

A

B

C

D

E

F

Recommended P.C.B Layout(Component Side)

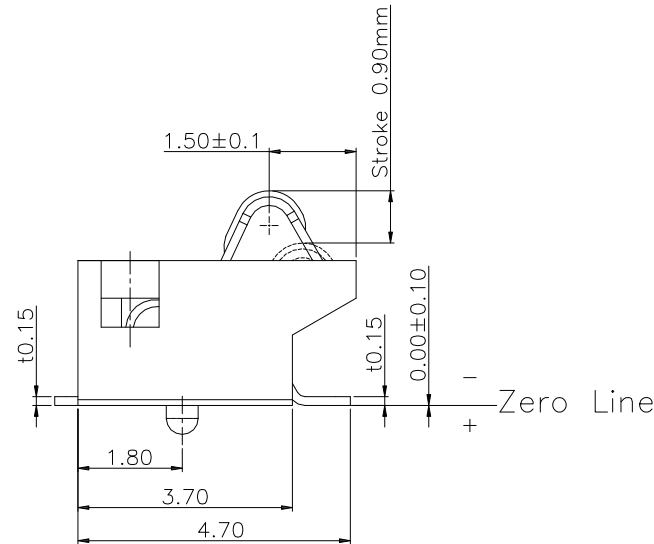
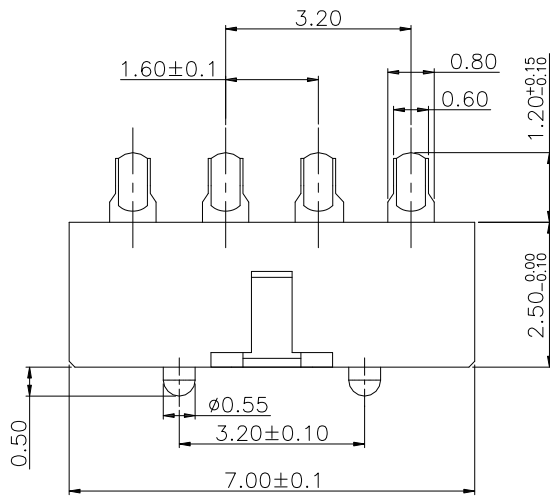
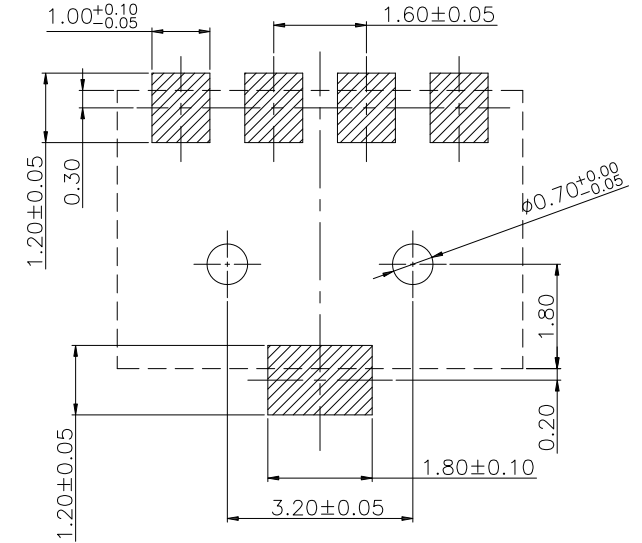
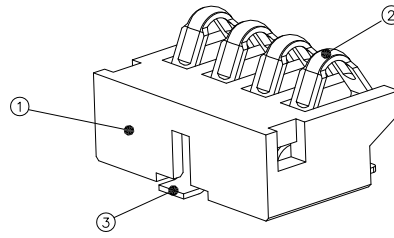
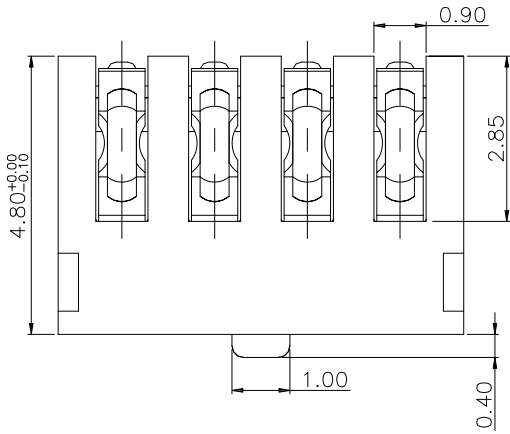

NOTE:



RG060011-MA004G101ZR

1. Selective plating
  - G1-05u" Gold over Nickel.
  - G2-Indicate Gold flash
  - G3-10u" Gold over Nickel.
  - G4-15u" Gold over Nickel.
  - G5-30u" Gold over Nickel.

3	Fork	Copper Alloy	———	Tin plated
2	Terminal	Copper Alloy	———	Gold plated
1	Housing	High Temp Plastic	Black	UL94V-0
NO.	DESCRIPTION	MATERIAL	COLOR	REMARK

PROPRIETARY NOTE:

This document contains confidential information and proprietary to Rego Electronics and shall not be reproduced or disclosed to other documents or used for any purpose other than that for which was obtained without the expressed written consent of Rego Electronics.

.X ± 0.30	APPROVED:	 <a href="http://www.rego.com.tw">http://www.rego.com.tw</a>	
.XX ± 0.20	CHECKED: Chris		
.XXX ± 0.15	DRAWN: Andy		
X* ± 3'	DRAWN: Vic		
	UNITS: mm	SCALE: NONE	TITLE: SPRING BATT. CONN. SMT TYPE
	PART NO: RG060011-MA004G101ZR		SHEET: 1 OF 2

D	06.6.2019
REV	DATE

1 2 3 4 5 6 7 8 9 10

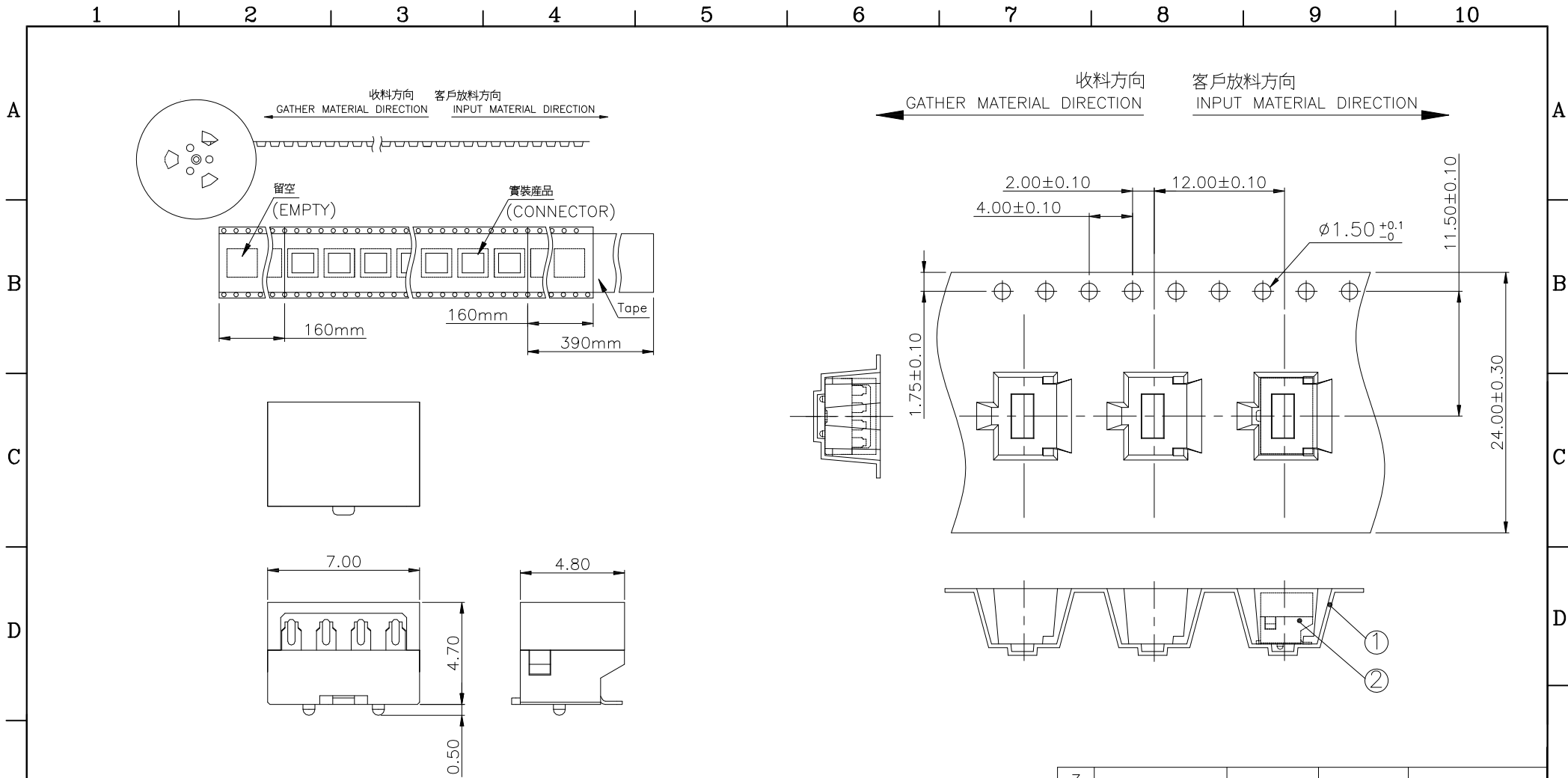

DETAIL (4:1)

Package Information

Part Number	Q'ty per reel
RG060011-MA004GX01ZR	1000pcs

NOTE: All dimensions tolerance are:  
 1. ±0.25mm unless otherwise noted.  
 2. Component load by 13" reel.

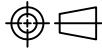
3				
2	product			RG060011-MA004GX01ZR
1	RELL	PS	BLACK	IPR0337-004-01
NO. DESCRIPTION		MATERIAL	COLOR	REMARK
<b>PROPRIETARY NOTE:</b> This document contains confidential information and proprietary to Rego Electronics and shall not be reproduced or disclosed to other documents or used for any purpose other than that for which was obtained without the expressed written consent of Rego Electronics.				
.X ± 0.30	APPROVED:	 <a href="http://www.rego.com.tw">http://www.rego.com.tw</a>		
.XX ± 0.20	CHECKED:			
.XXX ± 0.15	DRAWN:			
X* ± 3'		Vic	TITLE: SPRING BATT. CONN. SMT TYPE	
	UNITS:	SCALE:	PART NO: RG060011-MA004G101ZR	
	mm	NONE	SHEET: 2 OF 2	

D	06.6.2019
REV	DATE