

NOTES:

1.MATERIAL:

HOUSING:THERMOPLASTIC, HIGH TEMP, 30% G/F UL94 V-0
 COLOR:BLACK
 SHELL:STAINLESS STEEL
 CONTACT:COPPER ALLOY

2.FINISH:

CONTACT:GOLD PLATING ON CONTACT AREA
 100u" MIN. MATTE TIN PLATING ON SOLDERTAILS
 50u" MIN. NICKEL UNDERPLATING OVER ALL
 SHELL: 50u" MIN.NICKEL UNDERPLATING OVERALL
 NO PLATING ON BACK

3.MUST PRESS PIECE WITH WEIGHT DURING PRODUCTION

PIN DEFINITION

PIN	SIGNAL NAME	PIN
1	ML_LANE 0(p)	21
2	GND	22
3	ML_LANE 0(n)	23
4	ML_LANE 1(p)	24
5	GND	25
6	ML_LANE 1(n)	26
7	ML_LANE 2(p)	27
8	GND	28
9	ML_LANE 2(n)	29
10	ML_LANE 3(p)	30
11	GND	31
12	ML_LANE 3(n)	32
13	GND	33
14	GND	34
15	AUX CH (p)	35
16	GND	36
17	AUX CH (n)	37
18	Hot Plug Detect	38
19	Return	39
20	DP_PWR	40

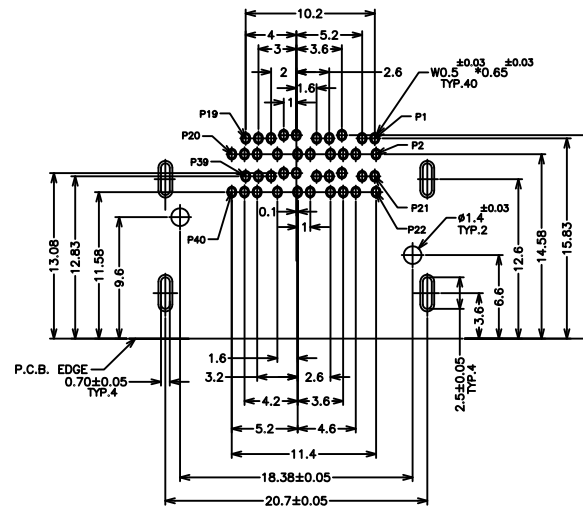

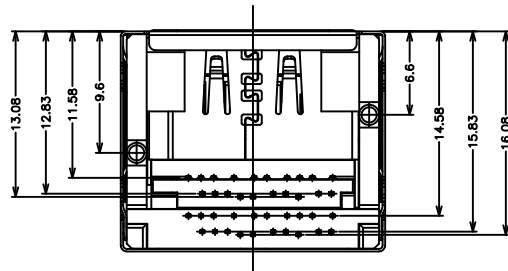
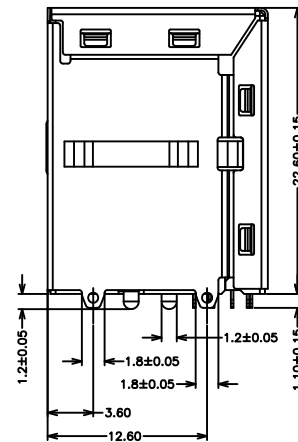
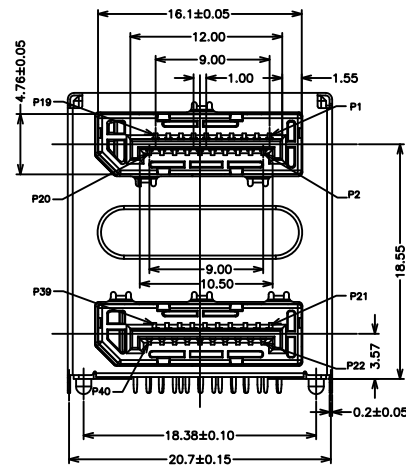
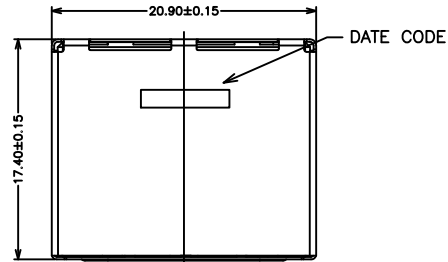

RECOMMEND P.C.BOARD LAYOUT
 PCB TOLERANCE:±0.05



30μ"	845-030-406CTRN
PLATING	PART NUMBER

PROPRIETARY NOTE:

This document contains confidential information and proprietary to Rego Electronics and shall not be reproduced or disclosed to other documents or used for any purpose other than that for which was obtained without the expressed written consent of Rego Electronics.

.X ± 0.30	APPROVED:	 TITLE: DISPLAYPORT DUAL-PORT R/A , DIP TYPE
.XX ± 0.20	CHECKED:	
.XXX ± 0.15	DRAWN:	
X* ± 3'		
 UNITS: mm SCALE: NONE		PART NO: 845-030-406CTRN SHEET: 1 OF 2

2	7.9.2018
REV	DATE