

1 2 3 4 5 6 7 8 9 10

A

A

1.0: MECHANICAL SPECIFICATION:

B

B

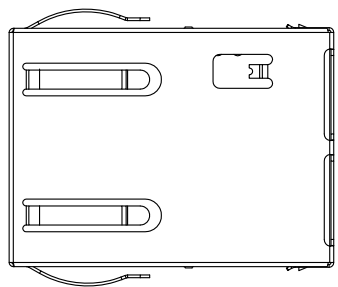

C

C

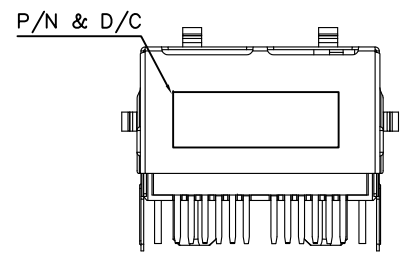
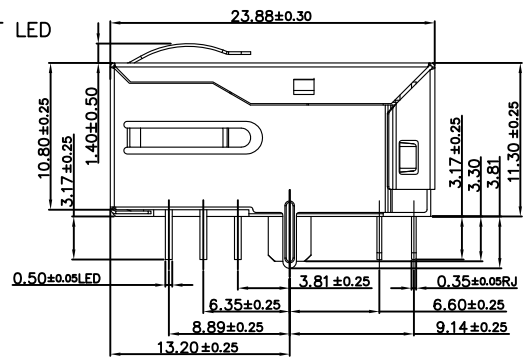
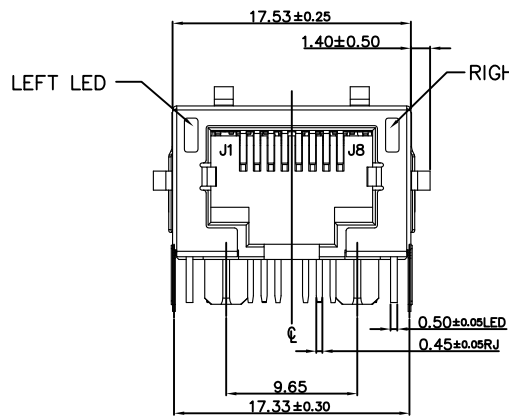

D

D

E

E

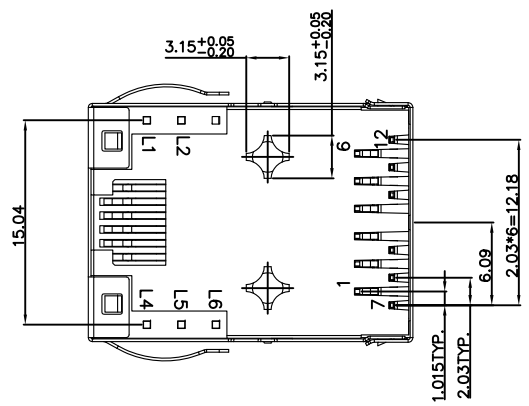

F

F

A	21.3.2018
REV	DATE

1 2 3 4 5 6 7 8 9 10

PROPRIETARY NOTE:
 This document contains confidential information and proprietary to Rego Electronics and shall not be reproduced or disclosed to other documents or used for any purpose other than that for which was obtained without the expressed written consent of Rego Electronics.

.X ± 0.30	APPROVED: Chris	 TITLE: RJ45 WITH 10G-5G-2.5G BASE-T TRANSFORMER SINGLE PORT JACK	
.XX ± 0.20	CHECKED: Denny		
.XXX ± 0.15	DRAWN: Bryan		
X' ± 3'		PART NO: KJ30818-MBCA2-600T	
	UNITS: mm	SCALE: NONE	SHEET: 1 OF 5

2.0: RECOMMEND P.C.B LAYOUT: (COMPONENT SIDE)
TOLERANCE: ±0.05mm

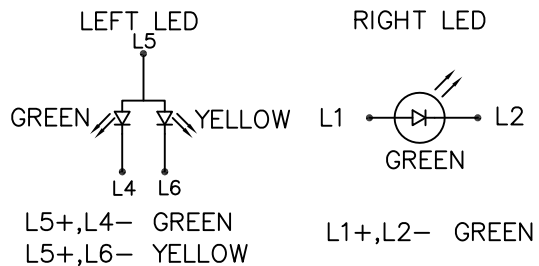
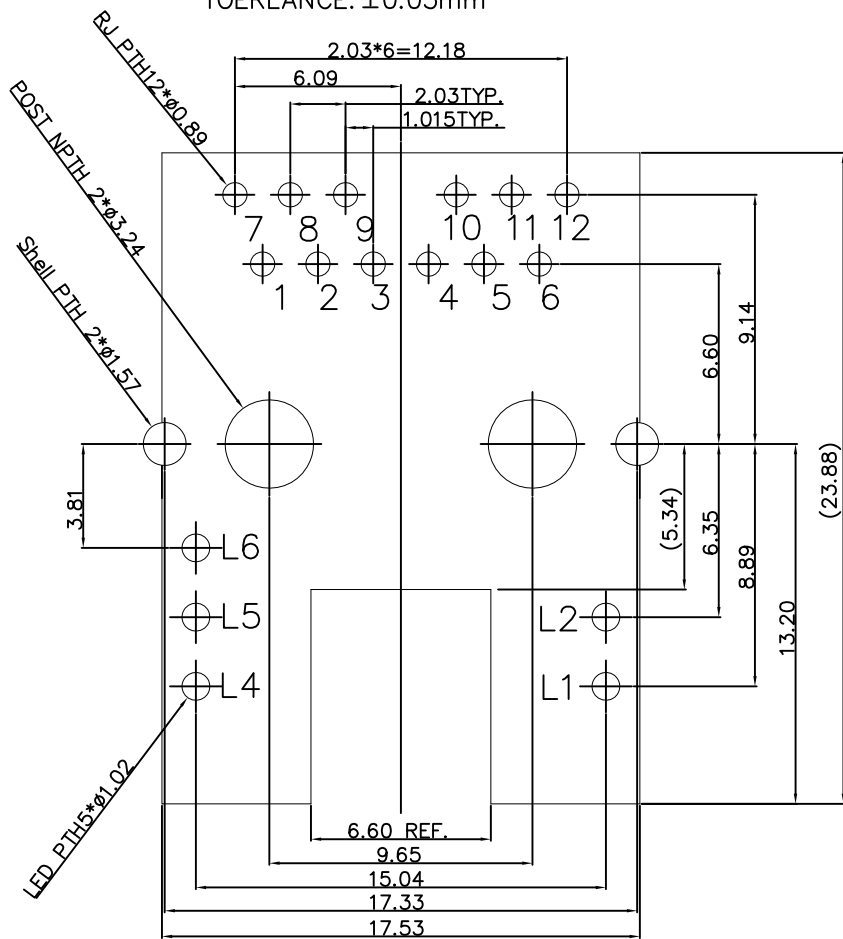

3.0: SCHEMATIC:

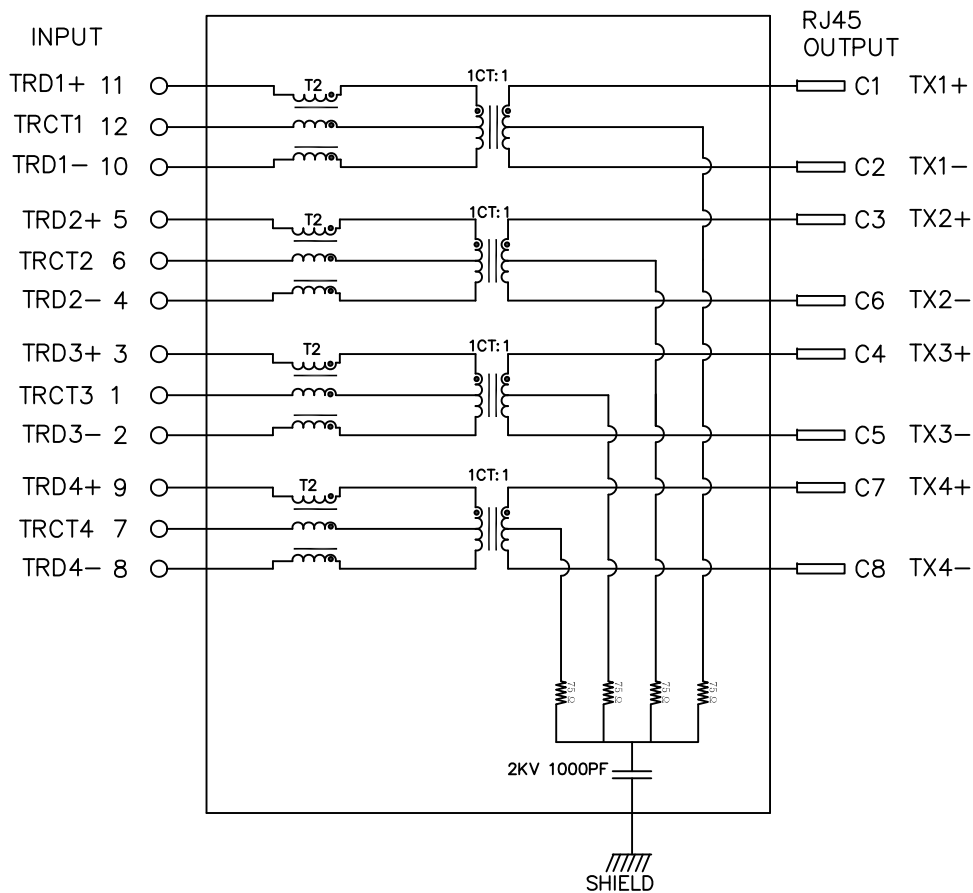

PROPRIETARY NOTE:

This document contains confidential information and proprietary to Rego Electronics and shall not be reproduced or disclosed to other documents or used for any purpose other than that for which was obtained without the expressed written consent of Rego Electronics.

.X ± 0.30	APPROVED: Chris	 http://www.rego.com.tw
.XX ± 0.20	CHECKED: Denny	
.XXX ± 0.15	DRAWN: Bryan	TITLE: RJ45 WITH 10G-5G-2.5G BASE-T TRANSFORMER SINGLE PORT JACK
X' ± 3'	UNITS: mm	SCALE: NONE
PART NO: KJ30818-MBCA2-600T		SHEET: 2 OF 5

A	21.3.2018
REV	DATE

A
B
C
D
E
F

5.0 NOTES:

5.1. MATERIAL SPECIFICATION;

- 1-1 Plastic Housings:
 - A. Housings: Thermoplastic, UL 94V-0
 - B. Transformer Housing: Thermoplastic,UL94V-0
- 1-2 Terminals:
 - A. RJ Contacts: Phosphor Bronze
 - B. RJ Solder Pins: Brass
 - C. Transformer Housing Solder Pins: Copper Alloy
 - D. LED Solder Pins: Copper Alloy
- 1-3 Shields:
 - A. Shield: SUS 304
- 1-4 Plating:
 - A. RJ Contacts: As P/N specified
 - B. RJ Solder Pins: 100u"min. Matte Tin over 50u" Nickel under-plating
 - C. LED Solder Pins: 100u"min. Tin over 50u" Nickel under-plating
 - D. Shield: Nickel-Plated

5.2. LED Code

Emitting Color	λ_p (nm)TYPE	Vf@I=20mA
Green	565	1.7-2.6V
Yellow	585	1.7-2.6V
Orange	610	1.7-2.6V

5.3. ELECTRICAL CHARACTERISTICS

- 1-1. OCL :@ 100K HZ , 0.1V , 140uH Min
- 1-2. Turn Ratio : 1CT:1CT +/- 5%
- 1-3.Insertion Loss : @ 1-400MHZ -2.0dB Max
@ 400-500MHZ -3.0dB Max
- 1-4. Return Loss :
@ 1-100MHZ -22dB Min.
@ 100MHZ-500MHZ -22+18.27LOG(f/100)dB Min.
- 1-5. Cross Talk : 1- 100 MHZ -28dB Min.
100-500MHZ -19dB Min.
- 1-6.Common Mode Rejection :
1-100 MHZ -35dB Min.
100-300 MHZ -30dB Min.
300-500 MHZ -25dB Min.
- 1-7. Common Mode to Differential Mode Rejection :
1-250 MHZ -30dB Min.
250-500 MHZ -22dB Min.
- 1-8.Isolation Hi-Pot : 2250VDC Min@ 60S



5.4. OPERATING & TEST REQUIRMENTS

Product is designed to meet electrical, mechanical and environmental performance requirements specified below. All tests are performed at ambient environmental conditions per MIL-STD-1344A and EIA-364 unless otherwise specified:

- 1-1 Operating Temperature Range: 0°C TO +70°C
- 1-2 Storage Temperature: -40°C to 85°C

A	21.3.2018
REV	DATE

PROPRIETARY NOTE:
This document contains confidential information and proprietary to Rego Electronics and shall not be reproduced or disclosed to other documents or used for any purpose other than that for which was obtained without the expressed written consent of Rego Electronics.

.X ± 0.30	APPROVED: Chris	 http://www.rego.com.tw
.XX ± 0.20	CHECKED: Denny	
.XXX±0.15	DRAWN: Bryan	
X* ± 3*		
	UNITS: mm	SCALE: NONE
TITLE: RJ45 WITH 10G-5G-2.5G BASE-T TRANSFORMER SINGLE PORT JACK		PART NO: KJ30818-MBCA2-600T
SHEET: 4		OF 5

A
B
C
D
E
F